

INSTALLATION INSTRUCTIONS

NuTone®

For help, call us
toll free!
1-888-336-3948

MODEL:
72WH244, 72WH244D
72WH246, 72WH246D
72WH244F, 72SS244DF
72WH246F, 72SS246DF
72SS244D, 72WH244DF
72SS246D, 72WH246DF
72SS304D, 72SS304DF
72WH304D, 72WH304DF

RECESSED MOUNTED, STEEL BATH CABINETS

MODEL NO.	WALL OPENING			OVERALL SIZE		
	W	H	D	W	H	D
72WH244	14-1/4	24	4	15	25	5
72WH246	14-1/4	24	6	15	25	7
72WH244F	14-1/4	24	4	15	25	5
72WH246F	14-1/4	24	6	15	25	7
72SS244D	14-1/4	24	4	15	25	5
72SS246D	14-1/4	24	6	15	25	7
72WH244D	14-1/4	24	4	15	25	5
72WH246D	14-1/4	24	6	15	25	7
72SS244DF	14-1/4	24	4	15	25	5
72SS246DF	14-1/4	24	6	15	25	7
72WH244DF	14-1/4	24	4	15	25	5
72WH246DF	14-1/4	24	6	15	25	7
72SS304D	23-1/4	29	4	24	30	5
72SS304DF	23-1/4	29	4	24	30	5
72WH304D	23-1/4	29	4	24	30	5
72WH304DF	23-1/4	29	4	24	30	5

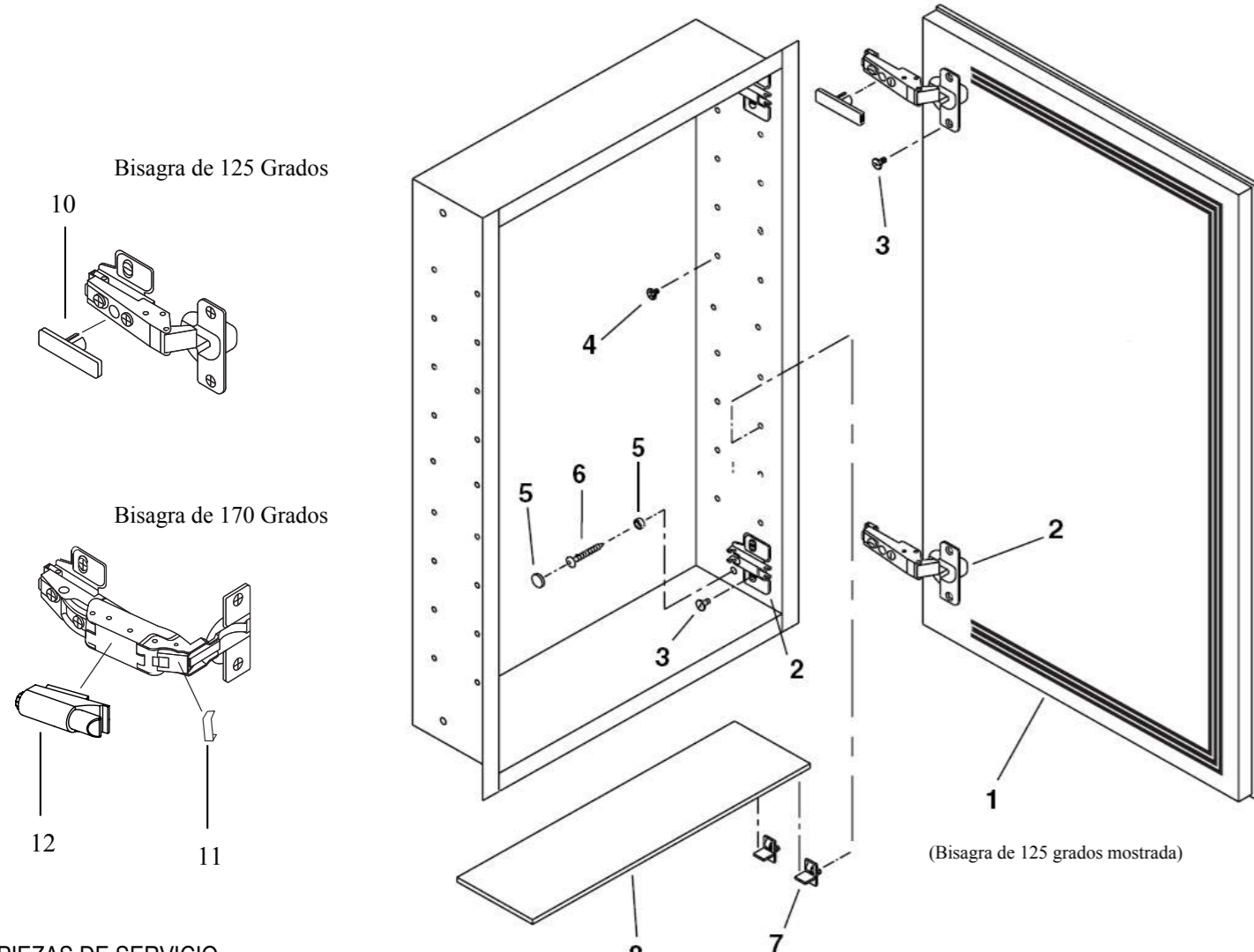

INSTALLATION of CABINET

- Carefully remove all packing material. Place hardware packages, shelves and door aside until needed.
- Determine desired location of cabinet on wall. Mark wall to show wall opening size (see dimension chart). Generally, the recommended height to the center of the cabinet is 64" from the floor. (Fig. 1)
- CAUTION: Wall studs, plumbing or electrical lines that interfere must be removed or relocated. Cut wall opening, being careful not to damage the surrounding wall surface. Insert framing to support all plaster board edges.
- Prepare the mounting screws by placing the screws into the clear plastic bases. (Fig. 2)
- Note: For ease of installation, an additional person is recommended. Insert cabinet into wall opening. (Fig. 3) Ensure the cabinet is plumb and level. If necessary use a carpenter's level and shim corners of cabinet. Secure the wall studs through the four (4) mounting holes inside cabinet, using the screws that have been placed into the plastic bases. (Fig. 4) Do not over tighten the mounting screws as the body side wall may bend and prevent proper shelf installation. Only tighten until they are flush with the body.
- Snap the screw covers over the screw bases. (Fig. 5)

PIEZAS DE SERVICIO

Key No.	Descripcion	72WH244	72WH244F	72WH244D	72WH244DF	72WH246D	72WH246DF	72SS244D
1	Ensamblaje De la Puerta	JRPWH24	JRPWH24F	JRPWH24D	JRPWH24DF	JRPWH24D	JRPWH24DF	JRPBK24D
2	Montaje de bisagra	JRP595	JRP595	JRP586D	JRP586D	JRP586D	JRP586D	JRP586D
3	Tornillo, bisagra	10-163-01	10-163-01	10-163-01	10-163-01	10-163-01	10-163-01	10-163-01
4	Tapones	29-826-01	29-826-01	29-826-01	29-826-01	29-826-01	29-826-01	29-826-02
5	Cubierta del tornillo	29-827-01	29-827-01	29-827-01	29-827-01	29-827-01	29-827-01	29-827-02
6	Tornillo de montaje #8 x 1 1/2*	*	*	*	*	*	*	*
7	Soporte de estante	29-842-01	29-842-01	29-842-01	29-842-01	29-842-01	29-842-01	29-842-02
8	Estante de vidrio	J3118701	J3118701	J3118701	J3118701	J3117101	J3117101	J3118701
9	Tira de Topes	111-695-01	111-695-01	111-695-01	111-695-01	111-695-01	111-695-01	111-695-01
10	Cubierta De la Bisagra (125 grados)	42-596-01	42-596-01	none	none	none	none	none
11	El Sujetador negro (170 grados)	none	none	42-594-01	42-594-01	42-594-01	42-594-01	42-594-01
12	Cierre Silencioso (170 grados)	none	none	42-586-02	42-586-02	42-586-02	42-586-02	42-586-02
	Bolsa de Accesorios	J2620501	J2620501	J2620501	J2620501	J2620501	J2620501	J2620502

Key No.	Descripcion	72SS244DF	72SS246D	72SS246DF	72SS304D	72SS304DF	72WH304D	72WH304DF
1	Ensamblaje De la Puerta	JRPBK24DF	JRPBK24D	JRPBK24DF	J10767603BK	J10767604BK	J10767603WH	J10767604WH
2	Montaje de bisagra	JRP586D	JRP586D	JRP586D	JRP587	JRP587	JRP587	JRP587
3	Tornillo, bisagra	10-163-01	10-163-01	10-163-01	10-163-01	10-163-01	10-163-01	10-163-01
4	Tapones	29-826-02	29-826-02	29-826-02	29-826-02	29-826-02	29-826-01	29-826-01
5	Cubierta del tornillo	29-827-02	29-827-02	29-827-02	29-827-02	29-827-02	29-827-01	29-827-01
6	Tornillo de montaje #8 x 1 1/2*	*	*	*	*	*	*	*
7	Soporte de estante	29-842-02	29-842-02	29-842-02	29-842-02	29-842-02	29-842-01	29-842-01
8	Estante de vidrio	J3118701	J3117101	J3117101	J3119901	J3119901	J3119901	J3119901
9	Tira de Topes	111-695-01	111-695-01	111-695-01	111-695-04	111-695-04	111-695-04	111-695-04
10	Cubierta De la Bisagra (125 grados)	none	none	none	42-596-01	42-596-01	42-596-01	42-596-01
11	El Sujetador negro (170 grados)	42-594-01	42-594-01	42-594-01	none	none	none	none
12	Cierre Silencioso (170 grados)	42-586-02	42-586-02	42-586-02	none	none	none	none
	Bolsa de Accesorios	J2620502	J2620502	J2620502	J2620502	J2620502	J2620501	J2620501

* Ferrería estandar - puede ser comprado localmente.

Pida los piezas de reemplazo por "NUMERO de PIEZA" - No por el "NUMERO DOMINANTE"

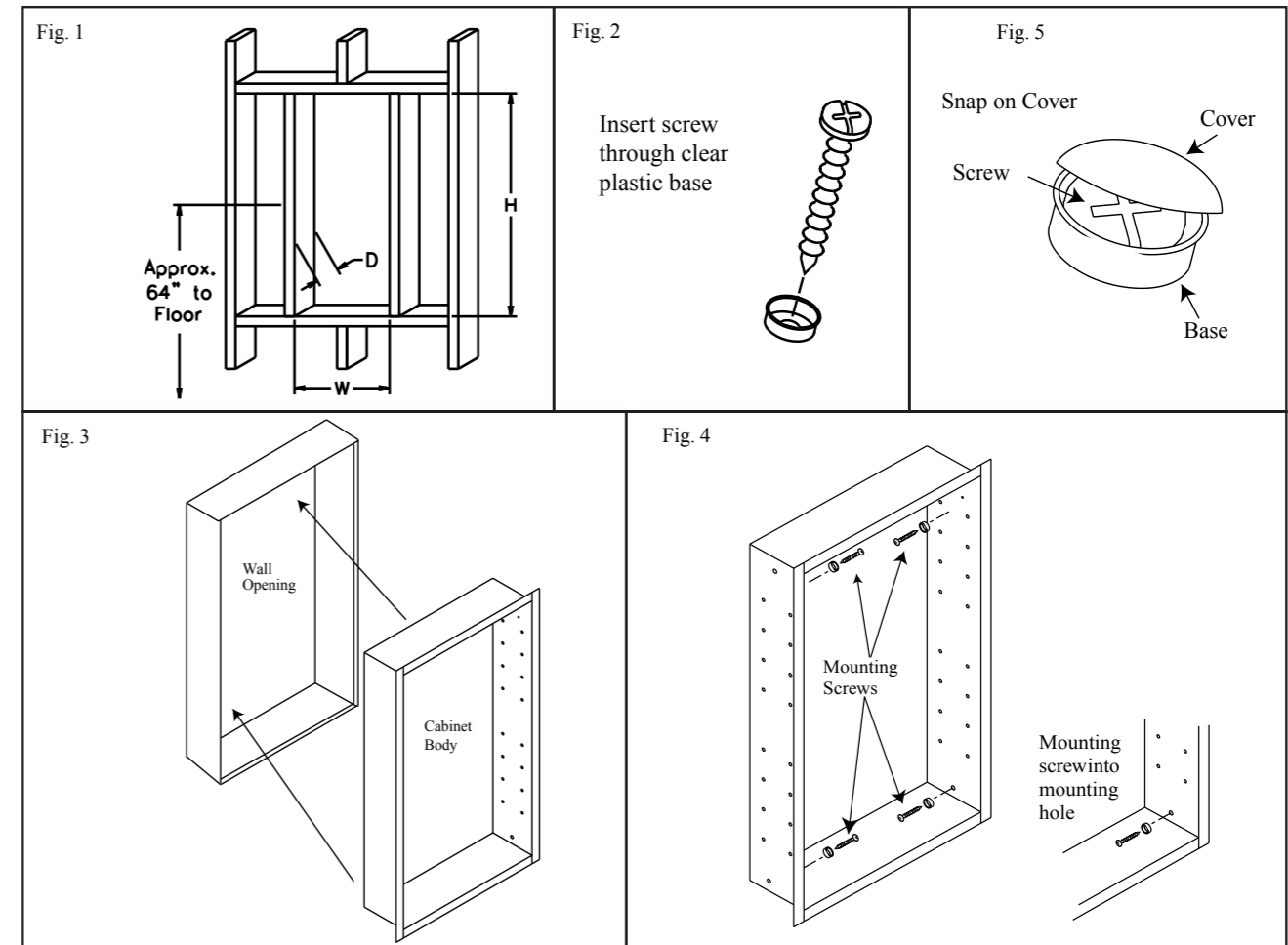

DO NOT OVER TORQUE (TIGHTEN) HINGE MOUNTING SCREWS. MANUALLY SCREW IN WITH PHILLIPS SCREW DRIVER UNTIL THE SCREW FEELS SECURE IN THE RIVET. IF USING A POWER DRILL, SET MAXIMUM TORQUE SETTING TO #5. OVERTIGHTENING THE SCREWS MAY/WILL CAUSE THE RIVET NUT TO LOOSEN FROM THE UNDERSIDE.

INSTALLATION of DOORS

- Remove hinges and screws from hardware bag. Mount hinge unit on door as shown in Fig. 6 or Fig. 7 securing with screws provided.
- Install the door by inserting door side of the hinge into the bracket on the body as shown;
 - 125 degree hinge
Insert door side of clip hinge as shown in Fig. 8
 - 170 degree hinge
Insert door side of clip hinge as shown in Fig. 9
- Check door for proper alignment. If the door needs to be adjusted please refer to the adjustment procedures in Fig. 10 or Fig. 11. Door edges should be aligned with to the face of the body.
- 125 degree hinge only:
Snap on hinge cover plate. (Fig. 12)
 - 170 degree hinge only: (Fig. 13)
After proper alignment of door, **REMOVE door from body by unclipping each hinge.** (see pg1)
Place the door on a secure flat surface with the hinges facing up. Use the diagrams in Figure 13 to apply the soft close attachment to either hinge.
NOTE: Only ONE hinge needs the attachment.
Only ONE attachment included.
 - Improper mounting
 - Position soft close attachment into place.
 - Slide hinge into place.
 - "Click" soft close attachment into place.

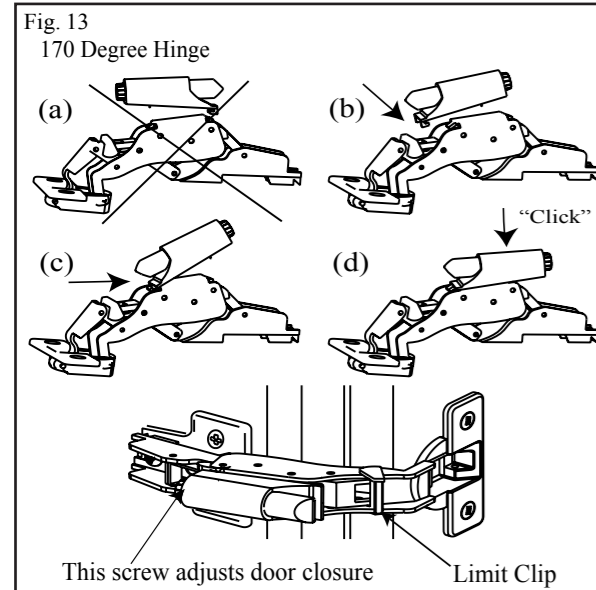

Instructions to remove soft close hinge attachment

- Remove door from body by unclipping each hinge. Place the door on a secure flat surface with the hinges facing up.
- Using a flat screwdriver, position under triangle as shown.
- Gently lift to remove hinge attachment.

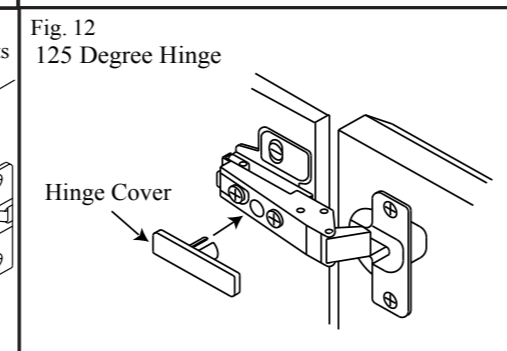
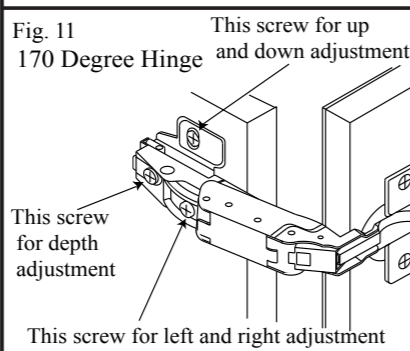
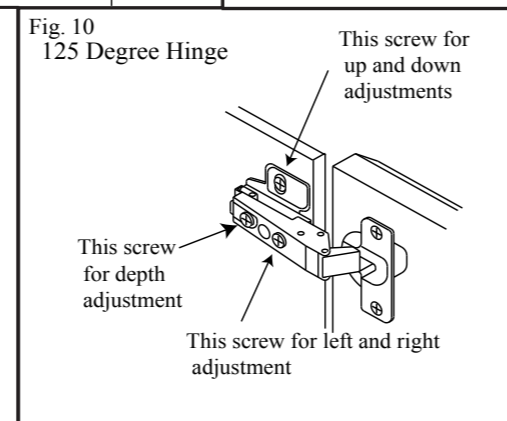
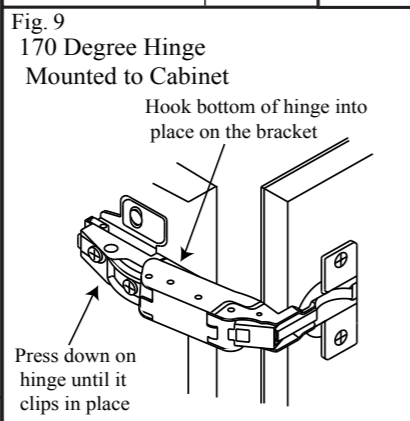
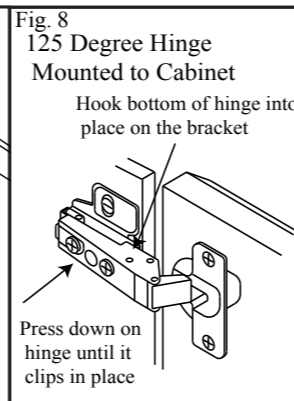
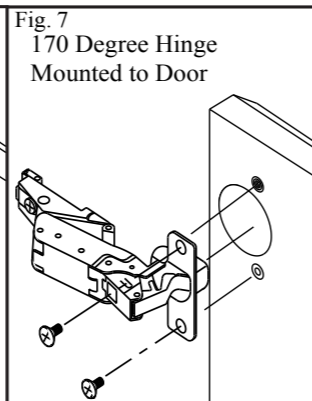
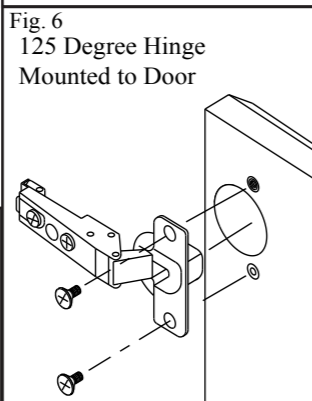
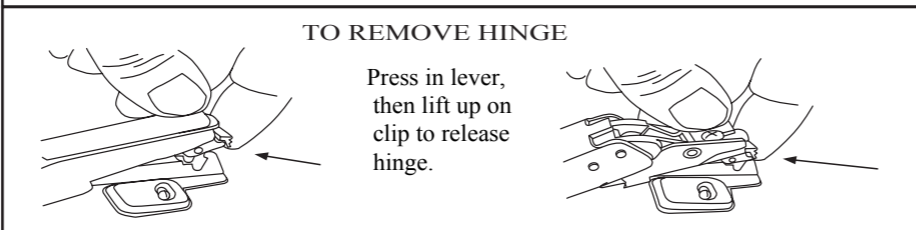
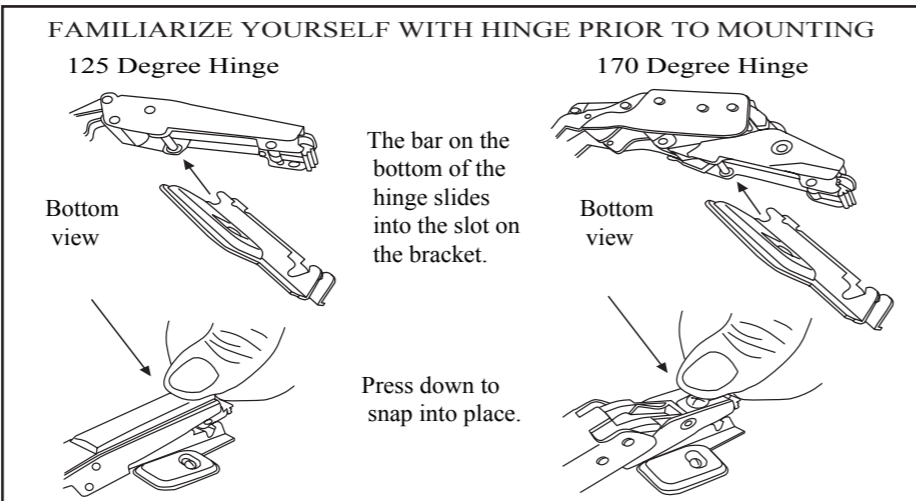
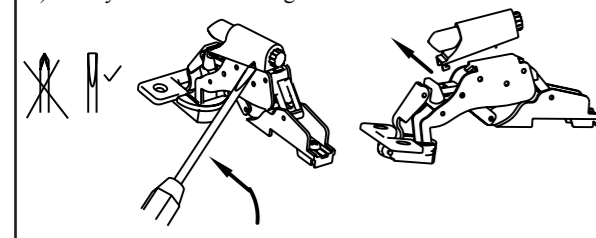

INSTALACION de ESTANTES Y TAPONES

- Nota: Revise detenidamente la ubicacion deseada para el estante. Los tapones de los hoyos son dificiles de quitar una vez metidos, es importante localizar la ubicacion del estante antes de instalar los tapones.
- Seleccione el lugar deseado de los estantes.
 - Ponga dos (2) soportes a cada lado de la ubicacion deseada. (Fig. 14)
 - Ponga los estantes sobre los soportes, presione y asi quedara el estante fijo en su lugar. (Fig. 14)
 - Saque los tapones de la bolsa y coloquelos en los agujeros restantes. (Fig. 15)

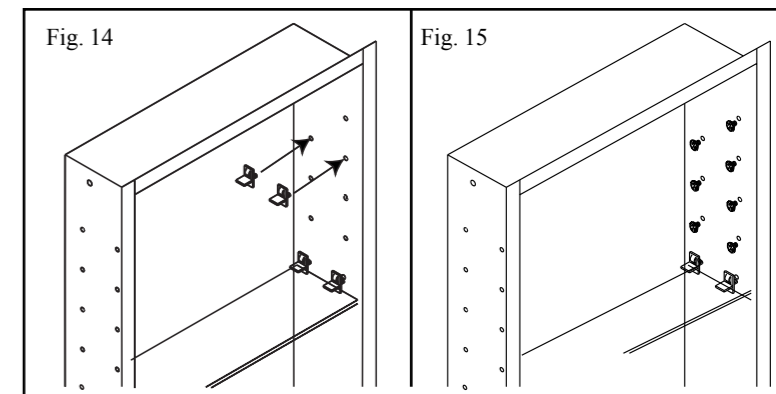

CUIDADO DEL ESPEJO

- Utilice solamente agua tibia y un trapo limpio, suave y sin pelusa.
- No utilice limpiadores con solucion a base de ammoniaco, vinagre o cloro.
- No utilice limpiadores en polvo o fibras de acero.
- Nunca rocíe el limpiador directamente en el espejo, especialmente en los bordes y la cubierta el la parte posterior. Aplique el limpiador al trapo y limpie. Seque a fondo.
- Mantenga el espejo seco. Un bano bien ventilado es importante.

Registracion del Producto

- Para registrar este producto visite a www.nutone.com

UN AÑO DE GARANTIA LIMITADA DE BROAN-NUTONE

Broan-NuTone le garantiza al consumidor comprador original de sus productos, que tales productos estaran libres de defectos en materiales o mano de obra por un periodo de un año a partir de la fecha de compra original. NO HAY OTRAS GARANTIAS EXPLICITAS O IMPLICITAS, INCLUYENDO, PERO NO LIMITADAS A GARANTIAS IMPLICITAS DE COMERCIALIZACION O APTITUD PARA UN PROPOSITO EN PARTICULAR. Durante este periodo de un año, Broan-NuTone reparara o cambiara, a su opcion cualquier producto o pieza que se encuentre defectuosa bajo uso y servicio normal. ESTA GARANTIA NO SE EXTIENDE A ARRANCADORES DE LAMPARAS FLUORESCENTES Y TUBOS. Esta garantia no cubre (a) mantenimiento y servicio normal o (b) cualquier producto o pieza que hayan sido sometidos a uso equivocado, negligencia, accidente, mantenimiento o reparacion indebida (excepto por Broan-NuTone), instalacion defectuosa o instalacion contraria a las instrucciones de instalacion. La duracion de cualquier garantia implicita se limita a un periodo de un año de acuerdo a como se especifica en la garantia explicita. Algunos estados no permiten limitacion a la duracion de una garantia implicita, por lo que esta limitacion tal vez no se aplica a su caso. LA OBLIGACION DE BROAN-NUTONE DE REPARAR O CAMBIAR, A OPCION DE BROAN-NUTONE, SERA EL UNICO Y EXCLUSIVO REMEDIO AL COMPRADOR BAJO ESTA GARANTIA. BROAN-NUTONE NO SERA RESPONSABLE POR DANOS INCIDENTALES, CONSECUENTES, O ESPECIALES QUE SURJAN DE O EN RELACION A EL USO O DESEMPEÑO DEL PRODUCTO. Algunos estados no permiten la exclusion o limitacion de danos incidentales o consecuentes, por lo que esta limitacion o exclusion tal vez no se aplica en su caso. Esta garantia le da derechos legales especificos, y tal vez puede tener otros derechos que varian de estado a estado. Esta garantia reemplaza todas las garantias anteriores. Para calificar para servicio bajo esta garantia, usted debe (a) notificar a Broan-NuTone a la direccion que aparece abajo o al telefono 1-888-336-3948, (b) dar el numero de modelo y la identificacion de pieza y (c) describir el defecto. Debera proveer evidencia de la fecha de la compra original a la hora de solicitar algun servicio en base a su garantia.

Broan-NuTone LLC, 926 West State Street, Hartford, WI 53027 (1-888-336-3948)

ATENCIÓN INSTALADORES:

De no apretar los tornillos de mas en la visagra, porfavor de aserlo manual mente con un desarmadorde crus hasta que usted piense que esta seguro. Si usted husa un taladro sin cable apliquelo en el numero #5. Apretandolos tornillos demasiado apretado podra safarse el tornillo de abajo.

INSTALACION de PUERTAS

1. Saque las bisagras y tornillos de la bolsa. Monte la bisagra en la puerta de acuerdo a la Fig.6 o Fig.7 usando los tornillos proporcionados.
 2. Instale la puerta metiendo el lado de la puerta de la bisagra dentro del soporte de acuerdo con lo demostrado.
 - A) Bisagra de 125 grados. Meta el lado de la puerta de la bisagra segun la Fig. 8
 - B) Bisagra de 170 grados. Meta el lado de la puerta de la bisagra segun la Fig. 9
 3. Asegurese que la alineacion sea adecuada. Si la puerta necesita un ajuste, por favor vea la Fig. 10 o Fig. 11 para los procedimientos. Los bordes de la puerta deben de alinear con la caratula del gabinete.
 4. A) Bisagra de 125 grados solamente: Ponga y presione la cubierta de la bisagra. (Fig. 12)
 B) Bisagra de 170 grados solamente: (Fig. 13) Despues de alinear la puerta, quite la puerta quitando las bisagras. Ponga la puerta en una superficie segura y plana con las bisagras hacia arriba. Use los diagramas en la Figura 13 para poner la pieza adjunta de cierre silencioso a cualquiera de las bisagras.
 NOTA: Solo UNA bisagra ocupa la pieza adjunta. Solo UNA pieza adjunta incluida.
 - (a) Montura inapropiada
 - (b) Ponga la pieza andjunta en su lugar
 - (c) Meta la bisagra en su lugar
 - (d) Presione la pieza adjunta en su lugar
- (C) Presione el sujetador negro.
 (D) Vuelva a instalar la puerta en el gabinete como lo muestra la Figura 11. Asegurese que la alineacion sea apropiada.

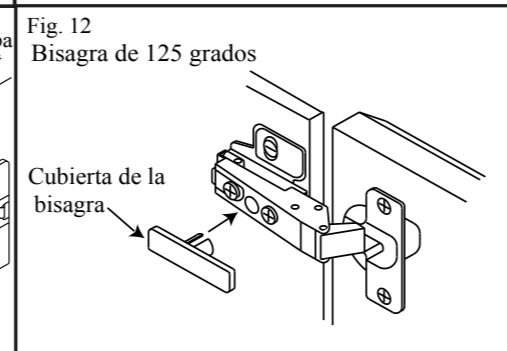
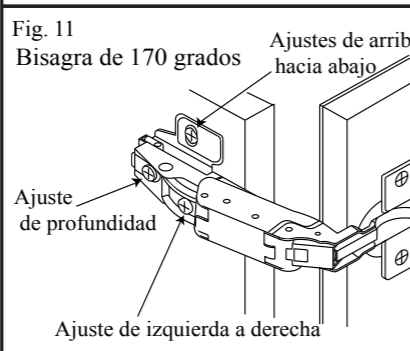
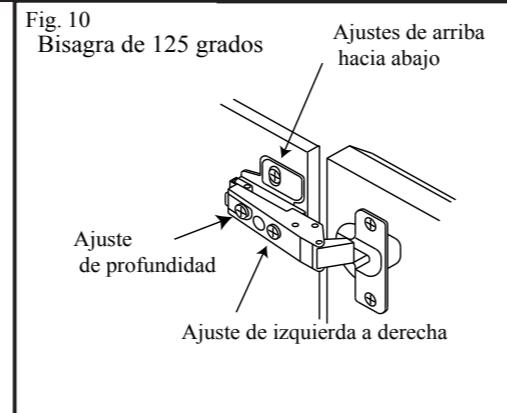
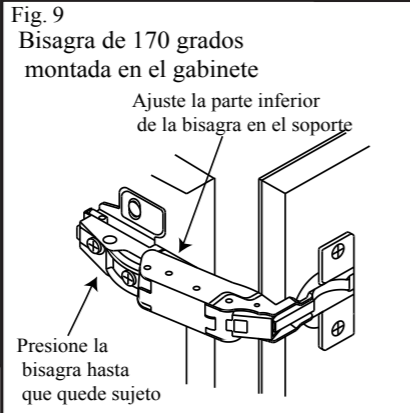
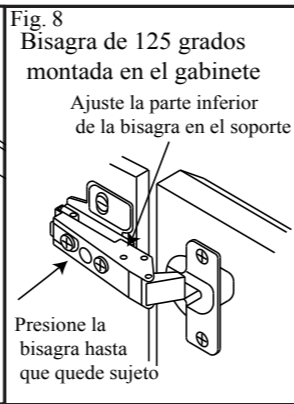
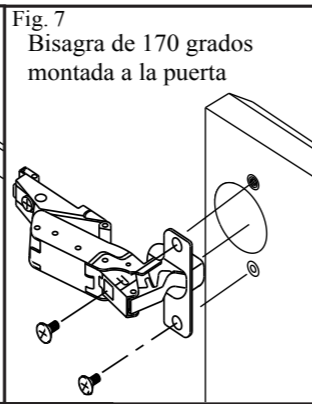
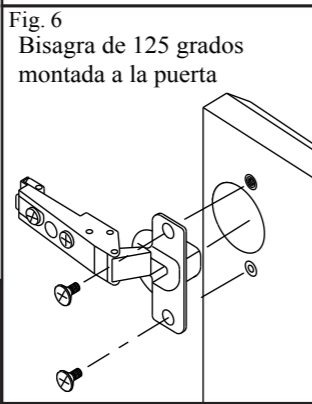
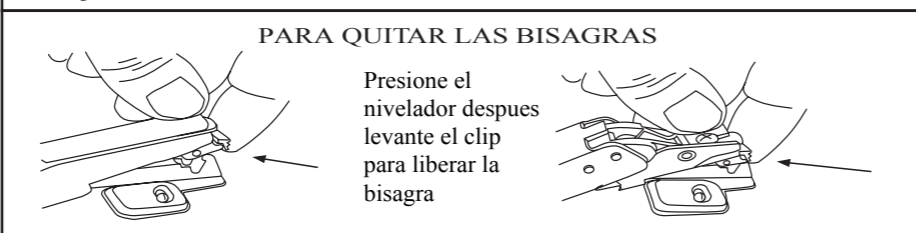
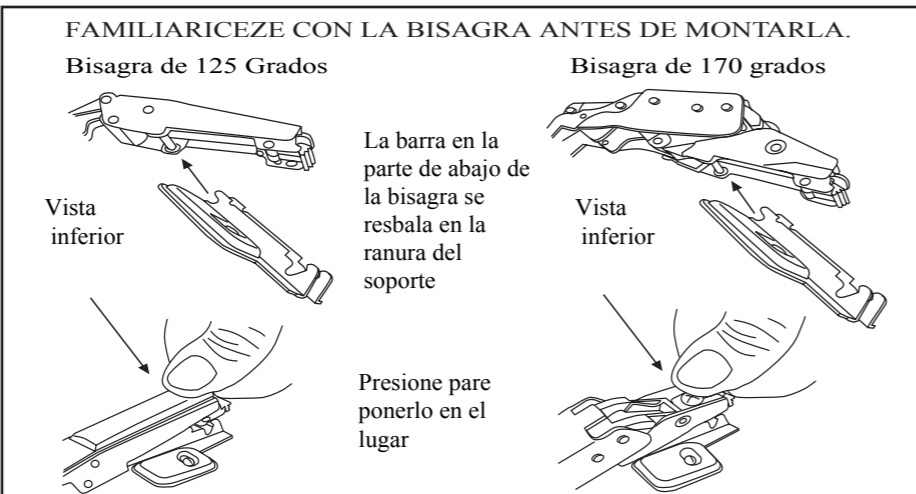
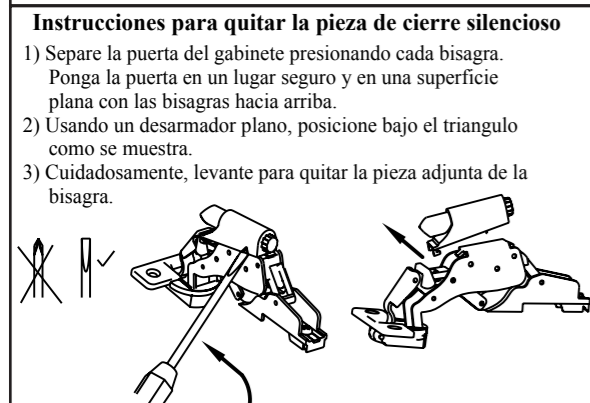
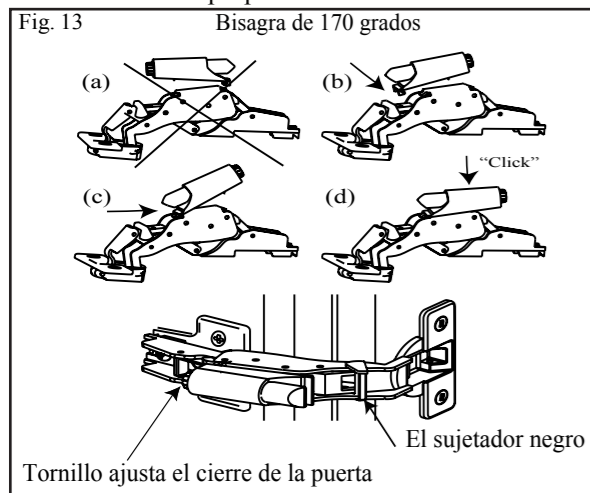

INSTALLATION of SHELVES, HOLE PLUGS AND BUMPERS

Note: Carefully review the shelf location desired. The hole plugs are difficult to remove once inserted so it is important to locate the shelves in the proper location before the hole plugs are installed.

1. Select where you want the shelves to be placed.
2. Insert two (2) shelf brackets at each end of the shelf location. (Fig. 14)
3. Set shelves in place on the shelf brackets, pressing down on shelf to lock in place. (Fig. 14)
4. Remove hole plugs from hardware bag and place in remaining holes. (Fig. 15)

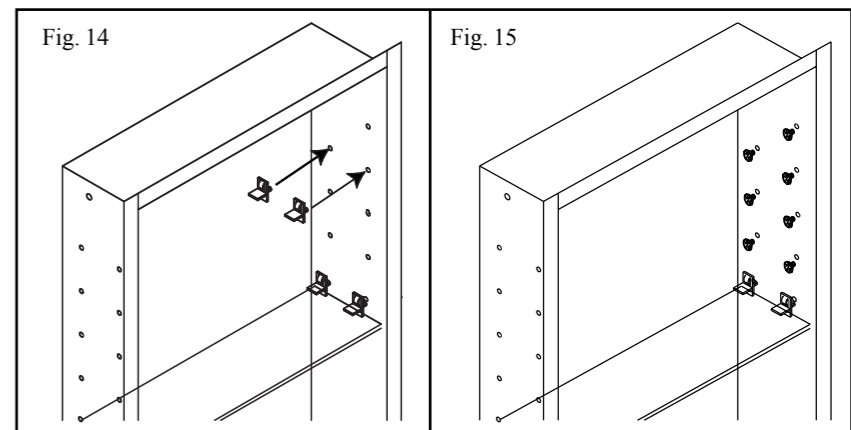

Product Registration

- To register this product, visit www.nutone.com

MIRROR CARE

- Use only clean warm water and a clean, soft, lint-free cloth.
- DO NOT USE cleaners that contain solutions of ammonia, vinegar, or chlorine.
- DO NOT USE powdered cleansers or steel wool.
- Never spray cleaning agent directly on mirror especially on exposed edges and mirror backing. Apply cleaner to soft cloth and wipe mirror. Dry mirror thoroughly.
- Keep mirror dry. A well ventilated bath room is important.

BROAN-NUTONE ONE YEAR LIMITED WARRANTY

Broan-NuTone warrants to the original consumer purchaser of its product that such products will be free from defects in materials or workmanship for a period of one year from the date of original purchase. THERE ARE NO OTHER WARRANTIES, EXPRESS OR IMPLIED, INCLUDING, BUT NOT LIMITED TO, IMPLIED WARRANTIES OF MERCHANTABILITY OR FITNESS FOR A PARTICULAR PURPOSE. During this one-year period, Broan-NuTone will, at its option, repair or replace, without charge, any product or part which is found to be defective under normal use and service. THIS WARRANTY DOES NOT EXTEND TO FLUORESCENT LAMP STARTERS AND TUBES. This warranty does not cover (a) normal maintenance and service or (b) any product or parts which have been subject to misuse, negligence, accident, improper maintenance or repair (other than by Broan-NuTone), faulty installation or installation contrary to recommended installation instructions.

The duration of any implied warranty is limited to the one-year period as specified for the express warranty. Some states do not allow limitation on how long an implied warranty lasts, so the above limitation may not apply to you. BROAN-NUTONE'S OBLIGATION TO REPAIR OR REPLACE, AT BROAN-NUTONE'S OPTION, SHALL BE THE PURCHASER'S SOLE AND EXCLUSIVE REMEDY UNDER THIS WARRANTY. BROAN-NUTONE SHALL NOT BE LIABLE FOR INCIDENTAL, CONSEQUENTIAL OR SPECIAL DAMAGES ARISING OUT OF OR IN CONNECTION WITH PRODUCT USE OR PERFORMANCE.

Some states do not allow the exclusion or limitation of incidental or consequential damages, so the above limitation or exclusion may not apply to you. This warranty gives you specific legal rights, and you may also have other rights, which vary from state to state. This warranty supersedes all prior warranties.

To qualify for warranty service, you must (a) notify Broan-NuTone at the address or telephone number stated below, (b) give the model number and part identification and (c) describe the nature of any defect in the product or part. At all time of requesting warranty service, you must present evidence of the original purchase date.

Broan-NuTone LLC, 926 West State Street, Hartford, WI 53027 (1-888-336-3948)

NuTone®

Para ayuda, llamenos gratis al 1-888-336-3948

MODELO:
 72WH244, 72WH244D
 72WH246, 72WH246D
 72WH244F, 72SS244DF
 72WH246F, 72SS246DF
 72SS244D, 72WH244DF
 72SS246D, 72WH246DF
 72SS304D, 72SS304DF
 72WH304D, 72WH304DF

GABINETE DE ACERO EMPOTRADO EN LA PARED

NUMERO DE MODELO	ABERTURA DE LA PARED			TOMANO TOTAL		
	W	H	D	W	H	D
72WH244	14-1/4	24	4	15	25	5
72WH246	14-1/4	24	6	15	25	7
72WH244F	14-1/4	24	4	15	25	5
72WH246F	14-1/4	24	6	15	25	7
72SS244D	14-1/4	24	4	15	25	5
72SS246D	14-1/4	24	6	15	25	7
72WH244D	14-1/4	24	4	15	25	5
72WH246D	14-1/4	24	6	15	25	7
72SS244DF	14-1/4	24	4	15	25	5
72SS246DF	14-1/4	24	6	15	25	7
72WH244DF	14-1/4	24	4	15	25	5
72WH246DF	14-1/4	24	6	15	25	7
72SS304D	23-1/4	29	4	24	30	5
72SS304DF	23-1/4	29	4	24	30	5
72WH304D	23-1/4	29	4	24	30	5
72WH304DF	23-1/4	29	4	24	30	5

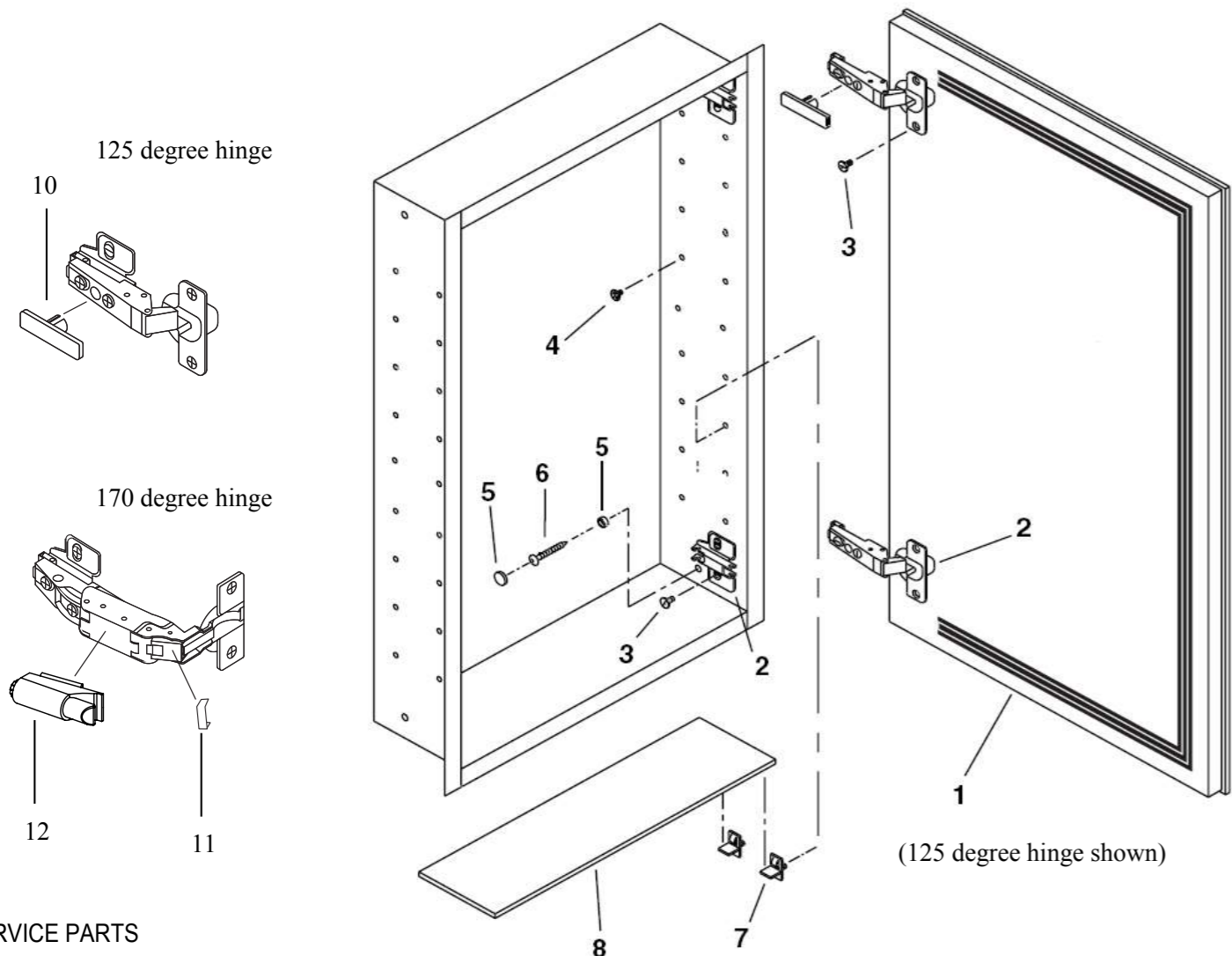

INSTALACION del GABINETE

1. Quite cuidadosamente todo el material del empaquetado. Coloque la puerta, los estantes y el paquete de herramientas a un lado hasta que se necesite.
2. Determine el lugar en la pared para el gabinete. Marque la pared para demostrar tamaño de la abertura de la pared (vease la grafica de dimensiones). Generalmente, la altura recomendada son 163cm del centro del gabinete hacia el suelo.
3. PRECAUCION: Lineas electricas o plomeria que interfieran, deberan de ser removidas o colocadas en otro lugar. Corte la abertura de la pared, con cuidado de no danar la pared de alrededor. Meta o ponga el marco para reforzar los bordes de yeso.

4. Prepare los tornillos de montaje colocando el tornillo en la base de plastico. (Fig. 2)
5. Nota: Para mas facilidad en la instalacion, se recomiendan dos personas. Meta el gabinete en la abertura de la pared. (Fig. 3) Asegurese que este vertical y al nivel. Si es necesario, rebaje las esquinas del gabinete. Asegure la pared atravez de los cuatro (4) hoyos para montar que se encuentran dentro del gabinete usando los tornillos que estan dentro de las bases de plastico. (Fig 4) No apriete excesivamente los tornillos de montaje ya que la parte lateral se puede doblar y prevenir la instalacion adecuada de los estantes. Apriete hasta que los tornillos esten parejos con el gabinete.
6. Encaje a presion las tapas sobre la cabeza del tornillo. (Fig.5)

SERVICE PARTS

Key No.	Description	72WH244	72WH244F	72WH244D	72WH244DF	72WH246D	72WH246DF	72SS244D
1	Door Assembly	JRPWH24	JRPWH24F	JRPWH24D	JRPWH24DF	JRPWH24D	JRPWH24DF	JRPBK24D
2	Hinge Assy (Door)	JRP595	JRP595	JRP586D	JRP586D	JRP586D	JRP586D	JRP586D
3	Hinge Screw	10-163-01	10-163-01	10-163-01	10-163-01	10-163-01	10-163-01	10-163-01
4	Hole Plug	29-826-01	29-826-01	29-826-01	29-826-01	29-826-01	29-826-01	29-826-02
5	Screw Cover	29-827-01	29-827-01	29-827-01	29-827-01	29-827-01	29-827-01	29-827-02
6	Mounting Screw #8 x 1 1/2	*	*	*	*	*	*	*
7	Shelf Supports	29-842-01	29-842-01	29-842-01	29-842-01	29-842-01	29-842-01	29-842-02
8	Glass Shelf	J3118701	J3118701	J3118701	J3118701	J3117101	J3117101	J3118701
9	Bumper Strip	111-695-01	111-695-01	111-695-01	111-695-01	111-695-01	111-695-01	111-695-01
10	Hinge Cover (125 degree hinge)	42-596-01	42-596-01	none	none	none	none	none
11	Limit Clip (170 degree hinge)	none	none	42-594-01	42-594-01	42-594-01	42-594-01	42-594-01
12	Soft Close (170 degree hinge)	none	none	42-586-02	42-586-02	42-586-02	42-586-02	42-586-02
	Hardware Bag Assembly	J2620501	J2620501	J2620501	J2620501	J2620501	J2620501	J2620502

Key No.	Description	72SS244DF	72SS246D	72SS246DF	72SS304D	72SS304DF	72WH304D	72WH304DF
1	Door Assembly	JRPBK24DF	JRPBK24D	JRPBK24DF	10767603BK	J10767604BK	J10767603WH	J10767604WH
2	Hinge Assy (Door)	JRP586D	JRP586D	JRP586D	JRP587	JRP587	JRP587	JRP587
3	Hinge Screw	10-163-01	10-163-01	10-163-01	10-163-01	10-163-01	10-163-01	10-163-01
4	Hole Plug	29-826-02	29-826-02	29-826-02	29-826-02	29-826-02	29-826-01	29-826-01
5	Screw Cover	29-827-02	29-827-02	29-827-02	29-827-02	29-827-02	29-827-01	29-827-01
6	Mounting Screw #8 x 1 1/2	*	*	*	*	*	*	*
7	Shelf Supports	29-842-02	29-842-02	29-842-02	29-842-02	29-842-02	29-842-01	29-842-01
8	Glass Shelf	J3118701	J3117101	J3117101	J3119901	J3119901	J3119901	J3119901
9	Bumper Strip	111-695-01	111-695-01	111-695-01	111-695-04	111-695-04	111-695-04	111-695-04
10	Hinge Cover (125 degree hinge)	none	none	none	42-596-01	42-596-01	42-596-01	42-596-01
11	Limit Clip (170 degree hinge)	42-594-01	42-594-01	42-594-01	none	none	none	none
12	Soft Close (170 degree hinge)	42-586-02	42-586-02	42-586-02	none	none	none	none
	Hardware Bag Assembly	J2620502	J2620502	J2620502	J2620502	J2620502	J2620501	J2620501

* Standard Hardware - may be purchased locally.
 Order Replacement parts by "Part Number" - not by "Key No."

